



Claremont

MODEL HIGHLIGHTS:

- MODERN ELEGANCE
- SPACIOUS CEILINGS
- ECONOMIC FLOOR PLAN

SQUARE FOOTAGE:

- MAIN LEVEL : 399 SQFT
- DECK OPTIONS : UP TO 852 SQFT

DESIGN OPTIONS:

- INTERIOR WALL PARTITIONS (NON-LOAD BEARING AND NON-BRACED) MAY BE DELETED FROM THE PLAN.
- KITCHEN & BATH ROOM CABINETS MAY BE OMITTED.
- WINDOWS AND DOORS MAY BE OMITTED EXCEPT AS REQUIRED BY CODE.
- FRONT DOOR CAN BE CHANGED TO SLIDING PATIO OR SWINGING DOOR.
- BATHROOM CAN BE CHANGED TO INCLUDE TUB OR SHOWER
- SIDE PORCH CAN BE FROM 12' TO 36' LONG
- SIDE PORCH CAN BE PLACED ON FRONT OR BACK
- END PORCH CAN BE ADDED ON GREAT ROOM
- SIDE PORCH CAN BE EXTENDED END PORCH

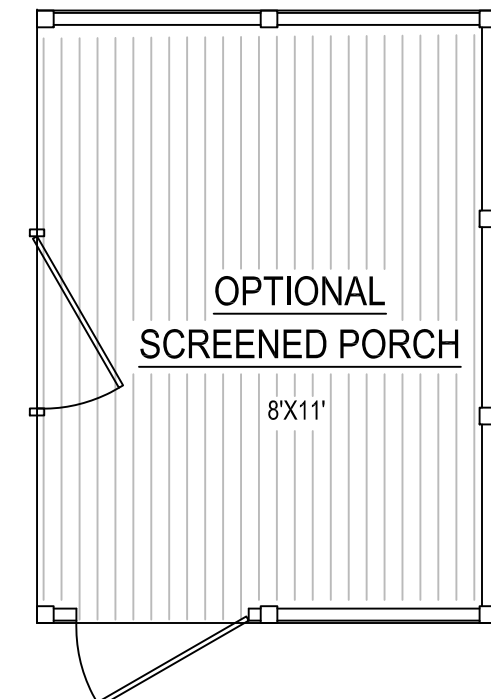

CEDAR CREEK BUILDERS
 ADDRESS: 1075 George Shaw RD
 Hopkinsville, KY 42240
 PHONE: 270-850-0453
 FAX: 270-889-9552
 EMAIL: ccbuilders@abccmailbox.net

REV#	DATE	BY	ISSUED	SCALE	DATE	CHECKED BY
A	08-20-23	JA		NTS	09/23/2023	M. MARTIN

CUSTOMER/PROJECT:
 CEDAR CREEK BUILDERS
 HOPKINSVILLE, KENTUCKY

FILE: CCB-Claremont
 SQ.FT.: AS SHOWN
 STATE: KY
 TYPE: TINY HOME
 MODEL: CLAREMONT
 DRAWING: 1ST STORY FLOOR PLAN
 SHEET: 4